

13112

FORD EXPLORER / MERCURY MOUNTAINEER

9/3/2020

FIT'S BELOW OEM RECEIVER HITCH

GROSS LOAD CAPACITY WHEN USED AS A WEIGHT CARRYING HITCH: 5,000 LBS. TRAILER WEIGHT & 500 LBS. TONGUE WEIGHT.
 GROSS LOAD CAPACITY WHEN USED AS A WEIGHT DISTRIBUTION HITCH: 8,000 LBS. TRAILER WEIGHT & 800 LBS. TONGUE WEIGHT

*****DO NOT EXCEED VEHICLE MANUFACTURER'S RECOMMENDED TOWING CAPACITY.*****

HAVING INSTALLATION QUESTIONS? CALL TECHNICAL SUPPORT AT 1-877-287-8634

Parts List			
ITEM	QTY	PART NUMBER	DESCRIPTION
1	1	1_2 FISHWIRE	1/2" FISHWIRE
2	2	CM-SP4	.250 x 1.50 x 3.00" SQUARE HOLE SPACER
3	4	20-00062	NUT, SER-FLANGE, 1/2-13 UNC, GRD8, YZ
4	4	10-10288	BOLT, CAR, 1/2-13 UNC, 2, GRD8, YZ
5	2	CM-116415-CT	CABLE TIE 11/64 X 15" 50# UV BLACK
6	2	CM-SP6	.250 x 1.00 x 3.00" SQUARE HOLE SPACER

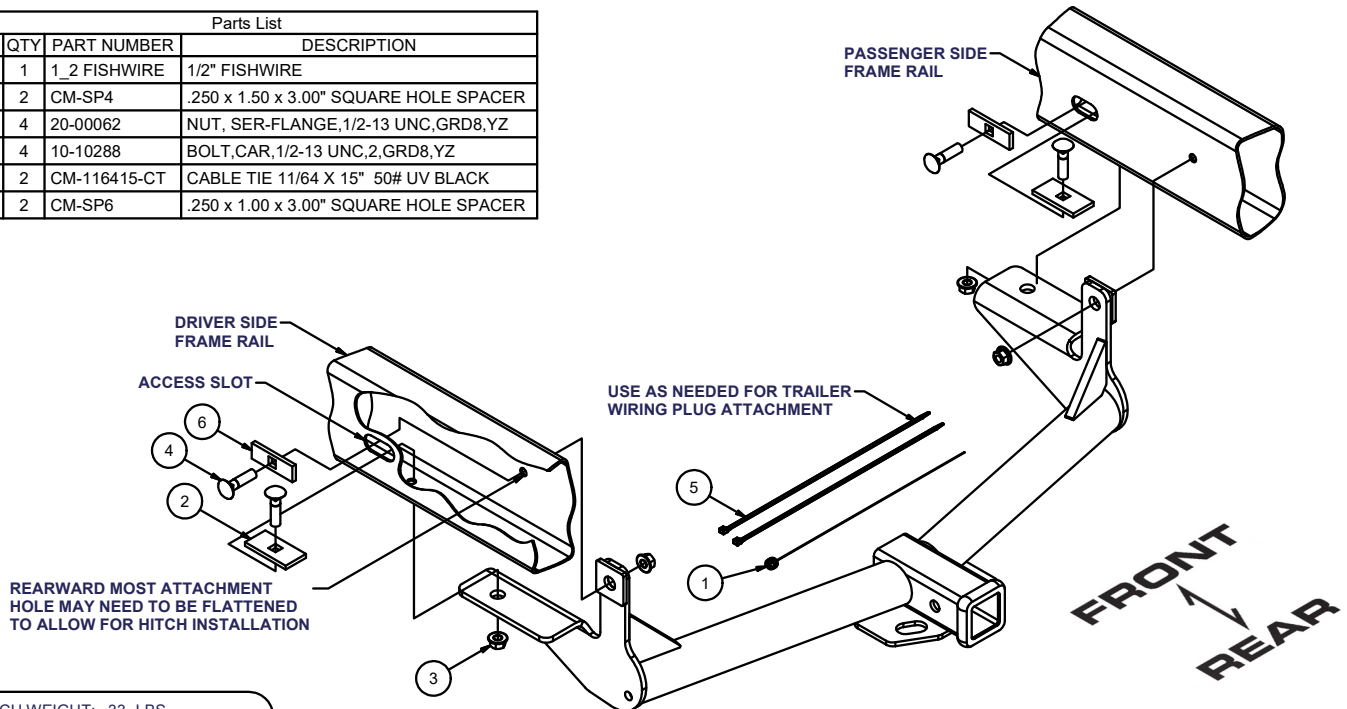

HITCH WEIGHT: 33 LBS.

INSTALL TIME

PROFESSIONAL: 30 MINUTES

NOVICE (DIY): 60 MINUTES

INSTALL NOTES:

- FISHWIRING REQUIRED
- NO DRILLING REQUIRED

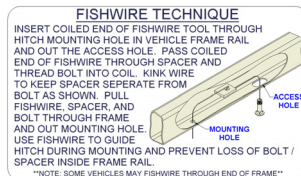

WARNING: IF VEHICLE IS EQUIPPED WITH O.E.M. HITCH DO NOT USE BOTH RECEIVERS AT THE SAME TIME. THIS MAY OVERLOAD AND CAUSE DAMAGE TO VEHICLE.

INSTALLATION STEPS

- 1) Remove the electrical bracket from bumper. Disconnect the rubber electrical connector from the metal bracket. Replace the bolt and return the bracket to the owner.
- 2) Install the carriage bolt and spacer using the fishwire for the forward attachment, insert fasteners through the access slot on either side of the frame rail.
- 3) Raise the hitch into position and hand tighten conical washer and hex nut. (being careful not to push the carriage bolt and block back into the frame)

Note: On some vehicles the rearward attachment hole may have some minor deformation. Use a hammer to flatten frame rail if there is interference with raising the hitch into position.

- 4) Using the fishwire, install the remaining carriage bolts and spacers for the rearward attachment, insert fasteners through the same access slot on either side of the frame rail.
- 5) Torque all 1/2 fasteners to 110 lb-ft.
- 6) Using the cable ties supplied, attach trailer wiring plug in a suitable location for future access. Re-install spare tire, if it was removed prior to hitch installation.

PERIODICALLY CHECK THIS RECEIVER HITCH TO ENSURE THAT ALL FASTENERS ARE TIGHT AND THAT ALL STRUCTURAL COMPONENTS ARE SOUND.

Curt Manufacturing Inc., warrants this product to be free of defects in material and/or workmanship at the time of retail purchase by the original purchaser. If the product is found to be defective, Curt Manufacturing Inc., may repair or replace the product, at their option, when the product is returned, prepaid, with proof of purchase. Alteration to, misuse of, or improper installation of this product voids the warranty. Curt Manufacturing Inc.'s liability is limited to repair or replacement of products found to be defective, and specifically excludes liability for incidental or consequential loss or damage.